

8" CASTING (NEENAH R-1976)

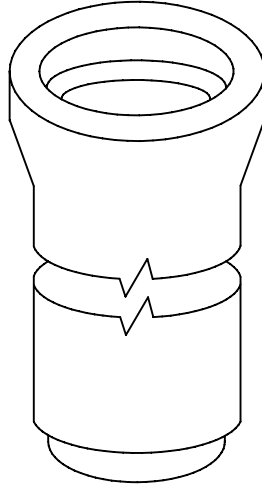

12" CONCRETE PIPE  
8' LONG (CUT TO LENGTH)

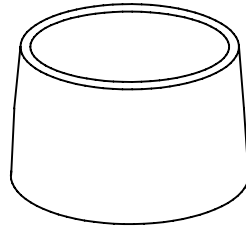

#18B PRESS SEAL BOOT

TOP OF CONCRETE TO  
FLOW LINE = 10.5"

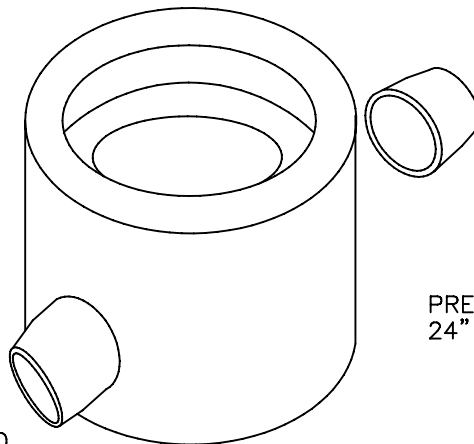

#6-2 PRESS SEAL BOOT  
(2 REQUIRED)

PRECAST STRUCTURE  
24" O.D. X 18" TALL

BOTTOM OF CONCRETE TO  
FLOW LINE = 4"

DARNALL CONCRETE PRODUCTS COMPANY

SAMPLING ACCESS MANHOLE STRUCTURE

DRAWING DATE: DECEMBER 1, 2000